

Stack Hight= 8.8+1=9.8±0.5

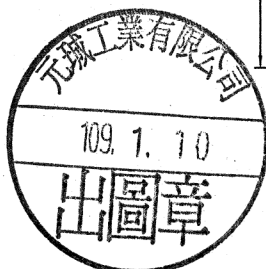
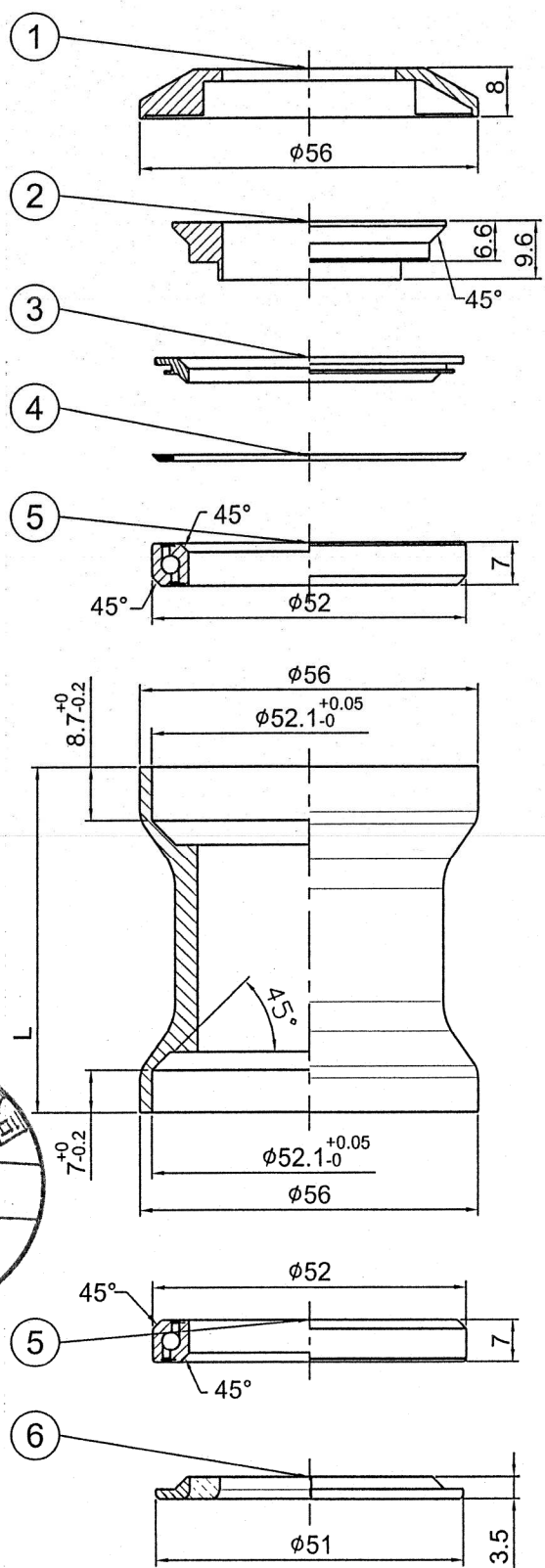

| | | |
|------------------|-----------------------|-------------------------|
| 型號 (Model No) | (6) 零件料號 (Item No) | $\phi D^{+0}_{-0.1}$ |
| PT-1863-1 | H6427-6 | $\phi 39.8^{+0}_{-0.1}$ |
| PT-1863-2 | H6427-7 | $\phi 30.0^{+0}_{-0.1}$ |

| NO | 零件名稱 (Item Name) | 零件料號 (Item No) | 材質 (Material) | 數量 (Qty) |
|-----|-------------------------------|-------------------|------------------|-------------|
| * 1 | 1 1/8"鋁上蓋 (穿線) TOP COVER | H1911(M版) | AL6061 | 1PCS |
| * 2 | 束環 (穿線)上8.7用 COMPRESSION RING | H2868C-1 | AL6061 | 1PCS |
| * 3 | 上塞 (上8.7用) CROWN RACE | H3273 | AL6061 | 1PCS |
| 4 | 防水圈 SEAL | A277 | Rubber | 2PCS |
| 5 | 軸承52x45°x7 SEALED BEARING | R413B | SUJ-2 | 2PCS |
| * 6 | 鋁下塞 (下7.0用) CROWN RACE | | AL7075 | 1PCS |

| | | | | | | | | | |
|----------|------|------|-----------|------------|---------------|---------|--------------|----|-------------|
| 4 | | | | | PT-1863 | | 上8.7 下7.0 | 名稱 | |
| 3 | | | | | 繪圖DRAWN BY | 日期 DATE | 校對 | | 圖號 |
| 2 | | | | | 林美紅 | 1090110 | CHKED BY | 單位 | |
| 1 | | | | | 設計DESIGNED BY | 日期 DATE | 陳勝松 | | 比例 SCALE |
| 編號 NO | 原有資料 | 修改資料 | 更改者 BY | 日期 DATE | | | 109.1.10 | | |

PRESTINE

元城工業有限公司